

► GENERAL FEATURES

- Robust sectional infeed roller and pressure plate for variable thickness feeding.
- Table surface is hard chromed and precision ground, offering smooth feeding effect and maximum wear resistance.
- Y- delta starter for motors.
- The pressure device at the infeed features overlapping layout for stable and uniform feeding pressure. Without any clearance, it is perfect for narrow workpieces (Optional).
- Overload protection devices available on feeding systems to protect the operator and the machine itself.
- Each cutterhead is mounted on SKF bearings for accurate performance and long service life.
- Automatic lubricator for vital machine parts such as conveyor and chain.
- Professional oil should be used on chain parts.

► 特點

- 分段組合式強力前送材粗面輪及分段組合前壓料板，對於厚度差異之木材同時加工，也能得到同樣之平面效果。
- 工作台面鍍硬鉻精密研磨送材順暢耐磨耗。
- 馬達採標Y-△兩段啓動。
- 前入料壓料採交叉排列(選購)，緊密沒空隙送材，壓力平均而且可加工較窄木料。
- 兩組送材系統過荷保護裝置，確保機械不損壞。
- 刀軸採用歐洲SKF軸承，品質優良，堅固耐用。
- 自動注油系統提供履帶，鏈條潤滑之方便性。
- 使用鏈條專用油。

► MACHINE IDENTIFICATION CODE / 機台型號識別

YA-XXX-A-B-D-R-T

Working width
加工寬度

Light duty
輕型

Gear feeding + Inverter
齒輪送料+變頻器

Helical cutterhead
螺旋刀

Vertical NC control
數控升降

Heavy duty
重型



YA-610AD



YA-635ARD



YA-400B

► HELICAL CUTTERHEAD (OPTIONAL)

- Precision machined by a CNC machining center for higher accuracy and greater cutting performance, this helical cutterhead provides light cutting load with minimum power consumption and low-noise emissions.
- Fitted with throw-away type carbide knife inserts.
- Prevent workpieces from wood tears when cutting.

螺旋刀頭 (選購配備)

- 此螺旋刀頭經CNC加工中心機精密加工而成。具有輕切削、無噪音、省動力之特性。
- 螺旋刀頭裝置捨棄式碳化鎢刀片。
- 加工木料時，不易缺裂。



► DIGITAL POSITIONING CONTROLLER (OPTIONAL)

The cutting thickness can be set by the digital positioning controller for higher thickness accuracy.

數值控制器 (選購配備)

加工厚度可採用數值控制器設定；確保更精準的加工厚度。

► HEAVY DUTY HELICAL CUTTERHEAD (OPTIONAL)

This cutterhead is specially designed with a particular cutting angle, providing low cutting resistance, low noise and high productivity, even for low horsepower machine.

重切削型螺旋刀頭 (選購配備)

此系列螺旋刀頭具有獨特的切削角設計，切削阻力大幅降低，無噪音。即使在低馬力機器上，也能發揮極高效率。



► AUTOMATIC LUBRICATOR

The machine is equipped with an automatic lubricator for delivering oil to vital machine parts such as the caterpillar chain slide ways. This ensures smooth running of the chain at all times, while making machine maintenance a simpler process.

THICKNESS SETTING WITH SAMPLE

The cutting thickness can be easily set by using a sample with the same thickness as the workpiece. This system is working in coordination with a limit switch for fast and convenient thickness control setting.

► 自動注油器

本機配備自動注油器，可提供履帶滑道之自動潤滑，確保履帶運轉順暢，避免人為潤滑疏忽損傷履帶。

厚度設定樣品

加工厚度設定也利用同厚度之木塊，配合極限開關控制，作方便快速之厚度設定。



► CONVENIENT KNIFE SETTING

The bottom cutterhead can be quickly pulled out from the side for easy and efficient knife setting.

STRAIGHT KNIFE CUTTERHEAD (STANDARD)

The machine is standard-equipped with straight knife cutterheads. Each one is fitted with four straight knives.

► 簡易校刀

下刀頭為可拉出式設計。如需校刀時，可將下刀頭拉出，提供快速方便的校刀作業。

平刀刀頭 (標準配件)

本機標準配備之刀頭為平刀式，刀頭裝有4支平刀。

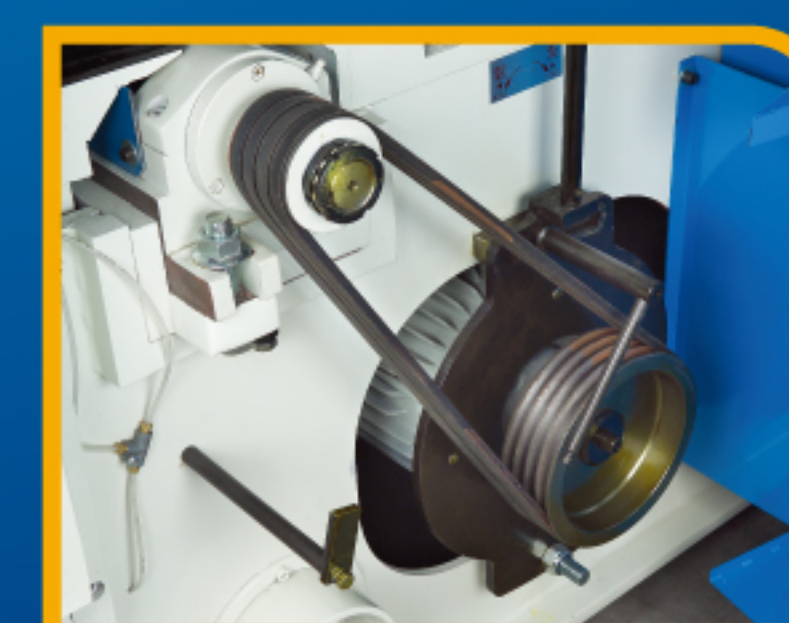

► CONVENIENT BELT TENSION ADJUSTMENT

- The safety belt guard can be fully opened to provide added convenience for belt tension adjustment.
- Belts are oil and heat-resistant.

皮帶調整方便

- 皮帶護蓋為全開式設計，提供皮帶鬆緊調整之方便性。
- 皮帶使用耐油、耐熱皮帶。

融 合 重 切 削 、 高 精 度 之 雙 面 鉋 木 機

A Double Surface Planer Designed for Heavy Duty Planing with High Accuracy...

YA-Series

► SPECIFICATIONS / 規格

MODEL / 型號	YA-635ARD	YA-400B	YA-450B	YA-610A	YA-960A
Maximum working width 最大加工寬度	635 mm (25")	405 mm (16")	450 mm (18")	610 mm (24")	960 mm (38")
Maximum working thickness 最大加工厚度	200 mm (8")	170 mm (7")	200 mm (8")	200 mm (8")	200 mm (8")
Minimum working thickness 最小加工厚度	10 mm	8 mm	8 mm	10 mm	10 mm
Minimum working length 最小加工長度	310 mm	250 mm	315 mm	310 mm	340 mm (13 3/8")
Numbers of spiral knife 各軸鉋刀數量	153 pcs	4 pcs	4 pcs	4 pcs	6T x 240 pcs x 2 sets
Knife size 鉋刀規格	TCT 15 x 15 x 2.5 mm	405 x 3 x 30 mm	450 x 3 x 30 mm	610 x 6.35 x 38 mm	TCT 15 x 15 x 2.5 mm
Diameter of knife 刀頭直徑	ø126 mm	ø101 mm	ø101 mm	ø126 mm	
Cutterhead Speed 刀軸迴轉速	5,000 rpm	4000 RPM	4000 RPM	4000 RPM	4000 RPM
Feed speed 無段變速迴轉速	7-20 m/min	7-20 m/min	7-20 m/min	7-20 m/min	7-16 or 12-30 m/min
Diameter of suction inlet tube 吸塵口徑	6"	5"	5"	6"	6" x 4 holes
Table size 工作台面積	27" x 103"	19" x 86"	21" x 93"	27" x 103"	1042 x 2616 mm (41" x 103")
Top cutter head motor 上刀軸馬達	20 (25 HP)	7.5 / 10 HP	7.5 / 10 HP	15 (20 HP)	30 HP
Bottom cutter head motor 下刀軸馬達	15 (20 HP)	5 / 7.5 HP	5 / 7.5 HP	10 (15 HP)	20 HP
Feeding motor 送材馬達	3 HP	2 HP	2 HP	3 HP	5 HP
Elevation motor 上部機座昇降馬達	1/2 HP	1/2 HP	1/2 HP	1/2 HP	2 HP
Machine dimensions (L x W x H) 機械尺寸	2667 x 1145 x 1720 mm	2200 x 900 x 1700 mm	2620 x 1245 x 1720 mm	2750 x 1145 x 1720 mm	2820 x 1745 x 1820 mm
Machine net weight 機械重量	2900 kg	1900 kg	2100 kg	3000 kg	4500 kgs
Packing dimension (L x W x H) 機械裝箱尺寸	2767 x 1245 x 1870 mm	2300 x 950 x 1850 mm	2670 x 2100 x 1400 mm	2767 x 1245 x 1870 mm	2920 x 1825 x 1870 mm
Machine gross weight 機械裝箱重量	3100 kg	2200 kg	2500 kg	3500 kg	5100 kgs

• All specifications and design characteristics shown in this catalogue are subject to change without notice.
• 規格變更恕不另行通知。

► DIMENSIONAL DRAWING / 機械尺寸示意圖

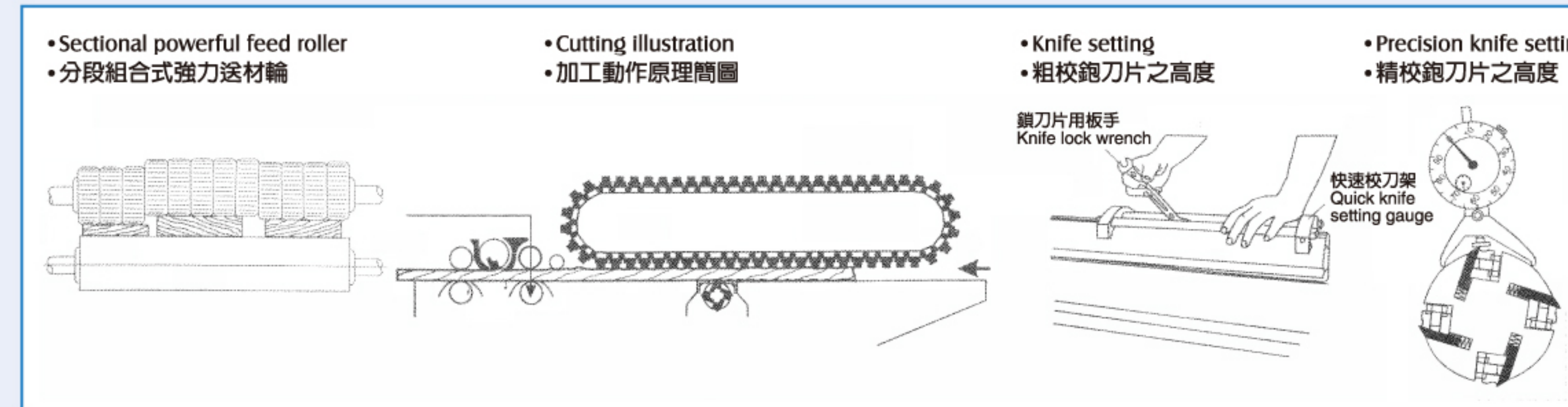
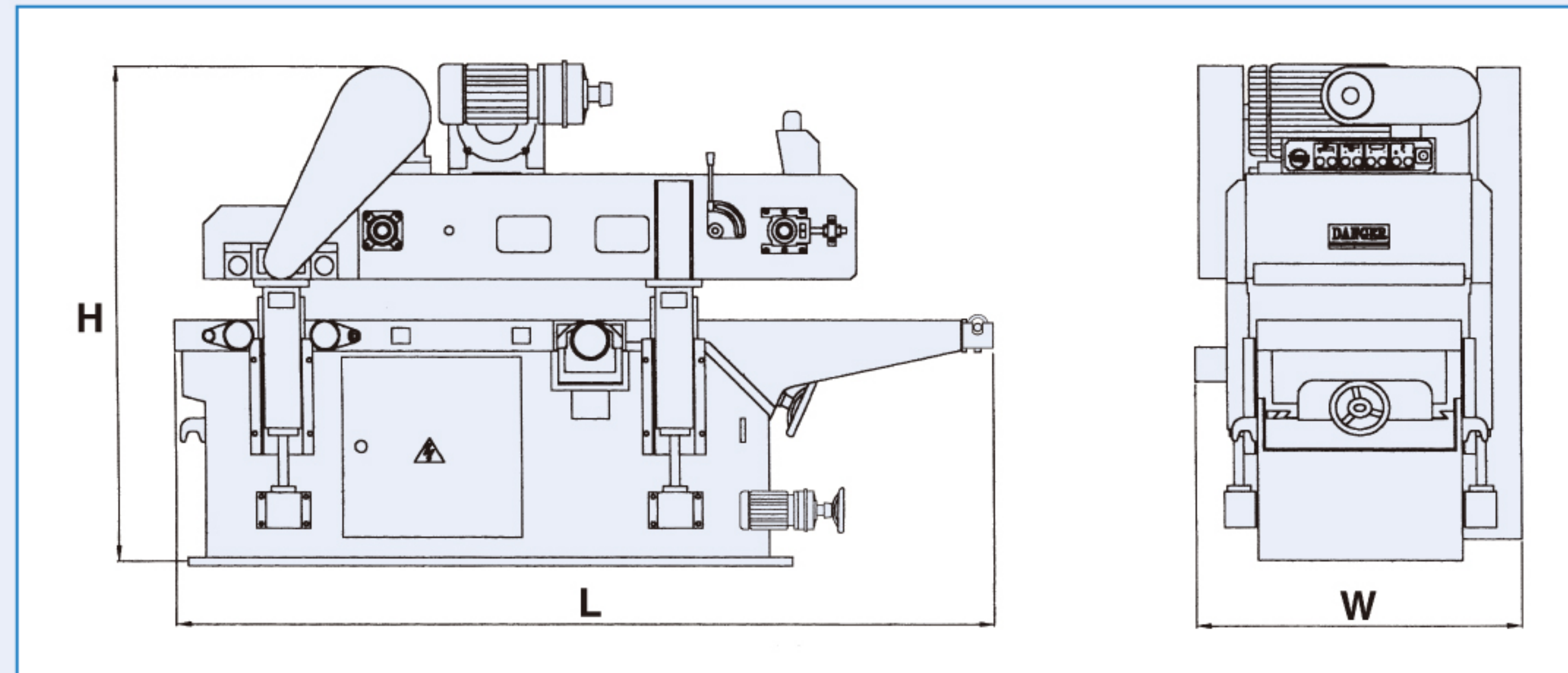

YUAN AN IRON WORKS CO., LTD.

圓鉋鐵工廠有限公司

No.302, Sec 2, Tanfu Rd., Tanzi District, Taichung City, Taiwan 427.

台中市潭子區潭富路二段302號

TEL:+886-4-2534-1931 / 2534-8660 FAX:+886-4-2534-9369

E-mail:an.planer@msa.hinet.net Http://www.yuanan.com.tw



1500_03_2018



DOUBLE SIDE PLANER

雙面鉋木機

YA-Series